

**SIDE VIEW**

GREEN: E+  
 WHITE: S+  
 BLACK: E-  
 RED: S-  
 SHIELD: GROUND

10FT. 4 COND. 30 AWG SHIELDED PTFE INSULATED CABLE TO INTERFACE WITH SIGNAL CONDITIONER/INDICATOR

CABLE EXIT  
 (5/16" DIA. MIN. HOLE  
 REQ'D FOR CABLE CLEARANCE  
 THROUGH MOUNTING SURFACE)

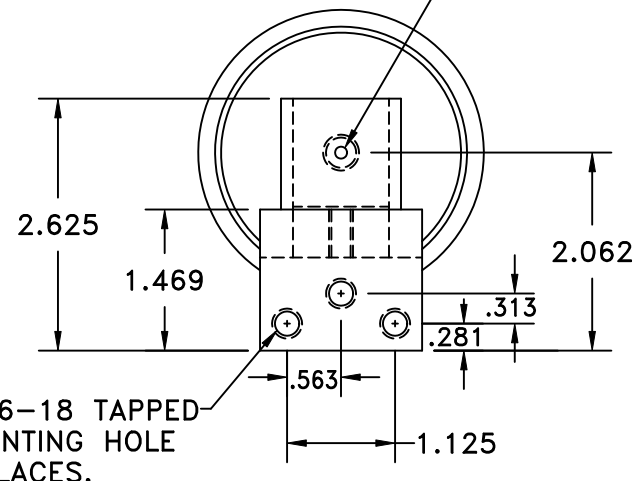

**REAR VIEW**

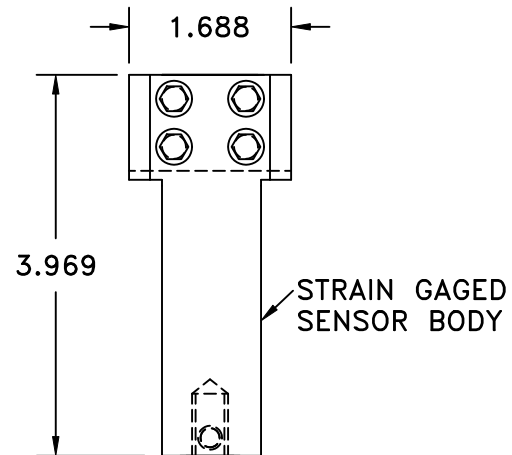

**TOP VIEW**

ROLLER NOT SHOWN

\* SENSOR MAY BE MOUNTED IN ANY POSITION/ORIENTATION AS LONG AS DIRECTION OF FORCE IS MAINTAINED.

**TENSION RANGES TO 50 LBS  
 WRAP ANGLE DEPENDENT**

**TMI Tension Measurement, inc**

Colorado, USA • Tension-Measurement.com  
 TEL. (303) 465-1011 • FAX (303) 466-9761

**CANTILEVER MOUNT TENSION SENSOR**

PART NO:  
 WC3-SERIES

MATERIAL:  
 ALUMINUM

TOLERANCES UNLESS OTHERWISE SPECIFIED:  
 U.S.O.  
 1 PLC. DEC. ±.030  
 2 PLC. DEC. ±.015  
 3 PLC. DEC. ±.005  
 ANGULAR ± 30"

SCALE: 1 = 2  
 DATE: 4-2001  
 BY: TMI