

TENSION SENSOR WITH 3 ROLLER FACE PLATE

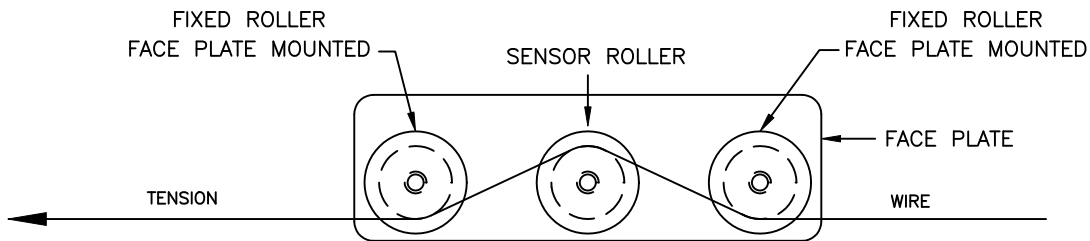

- COMPLETE TENSION SENSOR AS 1 UNIT
- ROLLER ALIGNMENT AND WRAP ANGLE SET BY FACE PLATE
- SENSOR CAN BE CALIBRATED BEFORE INSTALLATION
- CAN BE MOVED TO DIFFERENT LOCATIONS

SINGLE ROLLER TENSION SENSOR

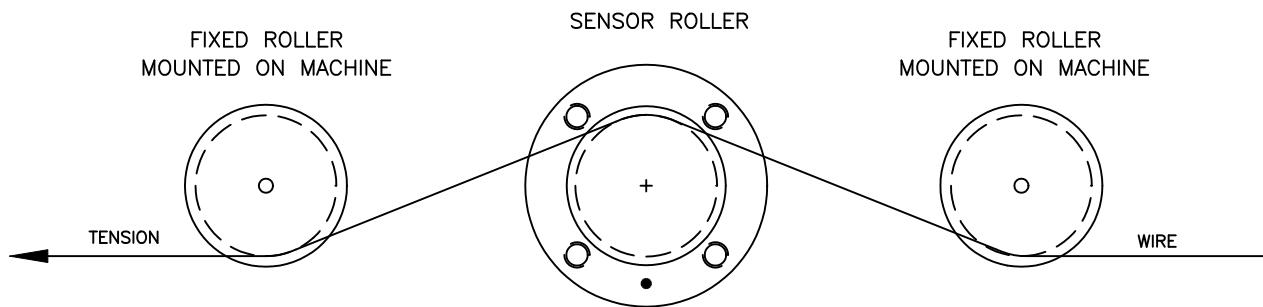

- REQUIRES 2 ADDITIONAL ROLLERS TO BE ALIGNED AND MOUNTED TO MACHINE FRAME
- MUST DETERMINE ROLLER POSITION AND WRAP ANGLE CREATED
- NOT LIMITED TO SPACING LIMITATIONS OF FACE PLATE - ROLLERS CAN BE SPREAD OUT
- LARGER DIAMETER ROLLERS CAN BE USED
- EASIER TO THREAD MATERIAL THROUGH THE MATERIAL PATH
- USE OF ROLLERS ALREADY EXISTING ON THE MACHINE
- SENSOR MUST BE CALIBRATED IN-SITU AFTER INSTALLATION

SHOWN ABOVE ARE SOME OF THE CONSIDERATION WHEN DECIDING THE STYLE OF SENSOR TO BE USED IN YOUR APPLICATION.

THE SINGLE ROLLER SENSOR DOES REQUIRE THE 2 FIXED ROLLER AS SHOWN. PAYOFFS TAKEUPS OR DANCER ARM ROLLERS DO NOT MAKE GOOD FIXED POINTS AS THEIR DIAMETER IS CHANGING OR POSITION IS CHANGING. THIS GREATLY EFFECT THE ACCURACY OF THE SENSOR.

FIGURE 10

3 ROLLER FACE PLATE OR SINGLE ROLLER SENSOR

TMS *Tension Measurement, Inc*

P.O. BOX 740755 ARVADA, CO. 80006 USA

TEL. (303) 465-1011 • FAX (303) 466-9761 • Tension-Measurement.com

**3 ROLLER FACE PLATE OR
SINGLE ROLLER SENSOR**

FIGURE
NO: TD007

DATE
8-31-2010